



ul. Zadziele 10, 32-406 Zakliczyn, POLAND

E-mail: support@aeroprakt.eu

Phone: +48 602 215854

AEROPRAKT

SERVICE BULLITEN

No. SB A-32-04

Release date: 19.07.2018

Effective date: 19.07.2018

Completion date:

Superseded notice: none

Model: A-32

Serial number(s) affected: All A32 aircraft to and including s/n 056

Repeating symbols:

Please, pay attention to the following symbols throughout this document marking important information.

▲ **WARNING:** Identifies an instruction, which if not followed may cause serious injury or even death.

■ **CAUTION:** Denotes an instruction, which if not followed, may cause severe damage.

◆ **NOTE:** Information useful for better handling.

1) Planning information**1.1) Aircraft affected**

All A32 airplanes, S/N to and including 056.

1.2) Reason

The rivets attaching the roof panel to the frame No.3 may become loose due to fatigue.

1.3) Subject

Rivets of the joint attaching the roof panel to the frame No.3.

1.4) Compliance

Compliance with this Service Bulletin is mandatory for all affected aircraft for flight safety reasons!

1.5) Approval

The technical content of this Service Bulletin has been approved by Aeroprakt.

1.6) Manpower

Estimated work: 1 to 1,5 man-hour.

1.7) Mass data

Mass change – none.

1.8) Revision of other documents

None.

1.9) Spare parts

The set of rivets is supplied by local dealer.

2) Spare parts information

Price of the mod kit: free of charge, less delivery cost.

3) Accomplishment / Instructions

▲ **WARNING:** Non-accomplishing this work may result in failure of fuselage.

- 3.1) Inspect the rivet joint of the roof panel and frame No.3 (Fig.1, 2, 3), check number of the rivets (intervals between them) and their condition.
- 3.2) If number of the rivets (intervals between them) are as shown in Fig.3 and the rivets are not loosened, this repair work is not needed.
- 3.3) If number of the rivets (intervals between them) are as shown in Fig.2 and the rivets are loosened, this repair work must be accomplished.
 - 3.3.1) Mark and drill with $\varnothing 3.1$ mm drill bit the holes for additional rivets according to Fig.3.
 - 3.3.2) Insert and set the additional $\varnothing 3 \times 8$ rivets.
 - 3.3.3) Undrill the loosened rivets with $\varnothing 3.1$ mm drill bit and install the new $\varnothing 3 \times 8$ rivets.
 - 3.3.4) Paint the rivet heads with color of the airplane.

4) Appendices:

The drawings below contain additional information.

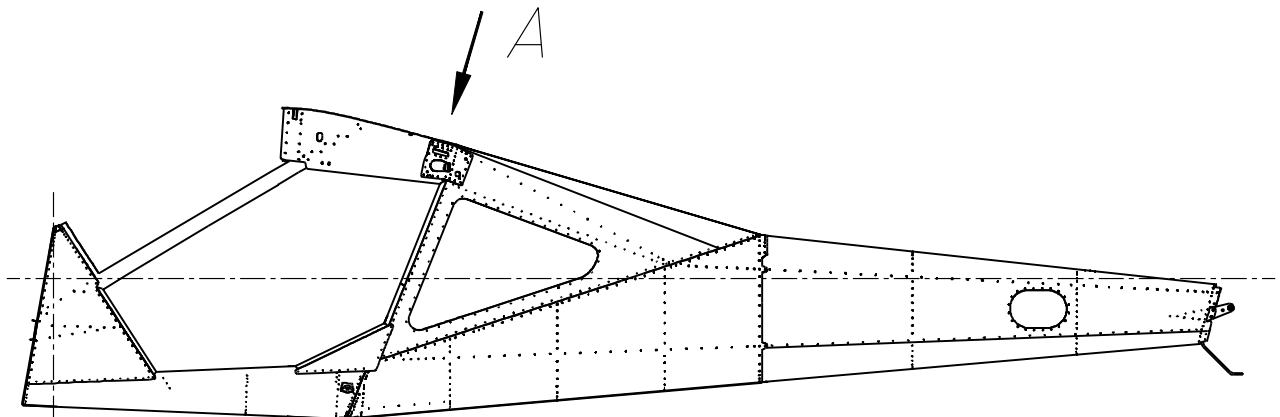

Fig.1

View on arrow A

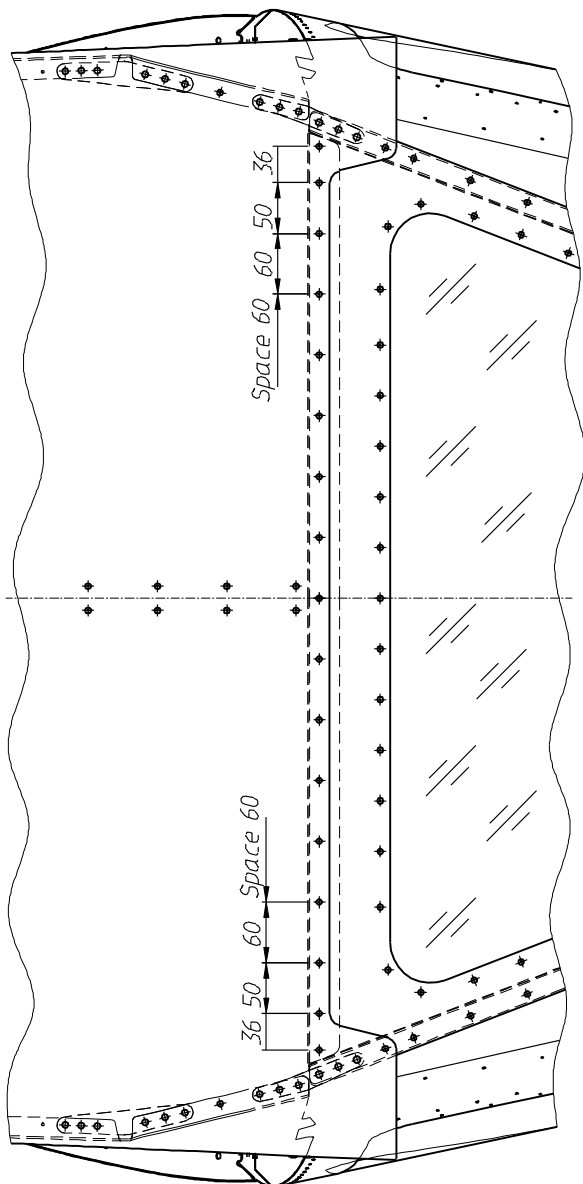

Fig.2

View on arrow A

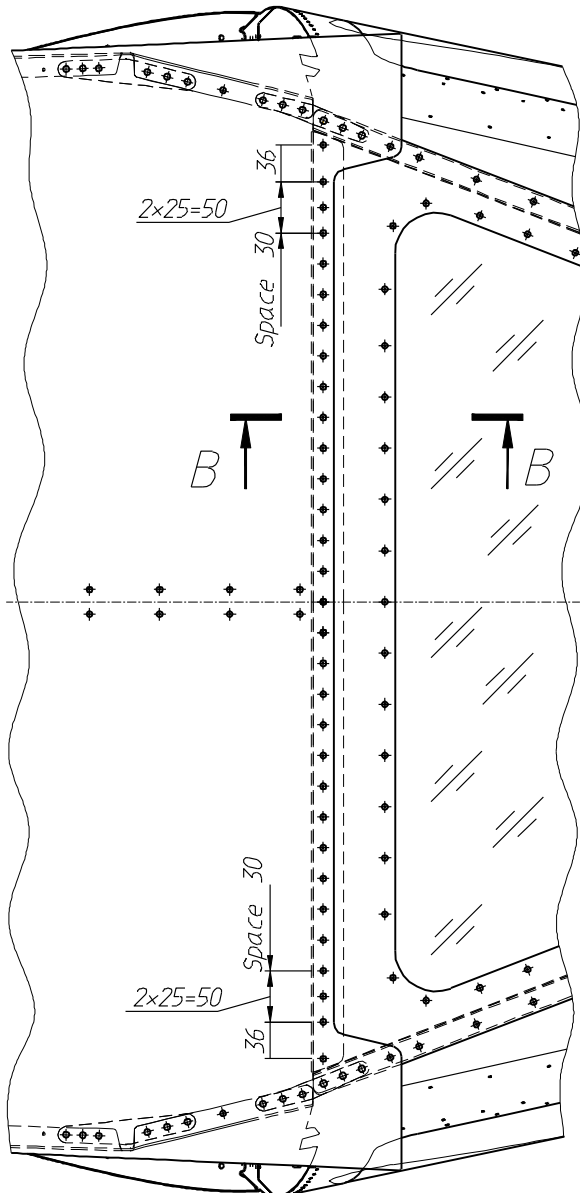

Fig.3

B - B

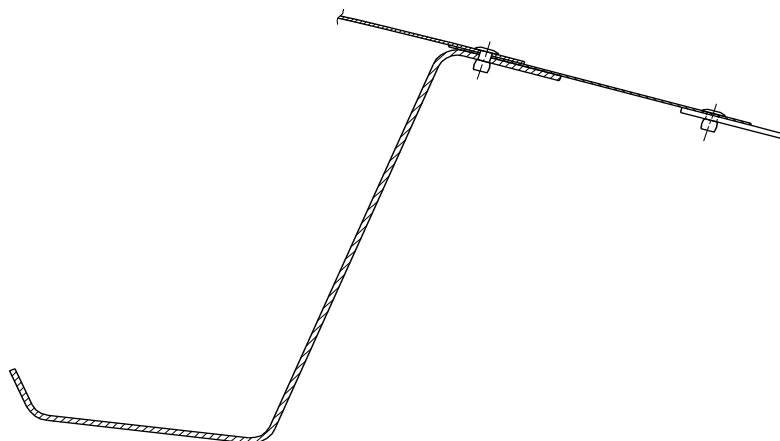

Fig.4