

Aeroprakt Manufacturing Sp. z o.o.



ul. Zadziele 10, 32-406 Zakliczyn, POLAND

E-mail: support@aeroprakt.eu

Phone: +48 602 215854

AEROPRAKT

SAFETY ALERT

No. SA A-22-03

Release date: July 2010

Effective date:

Completion date:

Superseded notice:

Model: A22LS

Serial number(s) affected: 1-42

Repeating symbols:

Please, pay attention to the following symbols throughout this document marking important information.

- ▼ **WARNING:** Identifies an instruction, which if not followed may cause serious injury or even death.
- **CAUTION:** Denotes an instruction, which if not followed, may cause severe damage.
- ◆ **NOTE:** Information useful for better handling.

1) Planning information

1.1) Aircraft affected

All versions of Aeroprakt-22LS airplanes series No. 1-42

1.2) Reason

It was found out that an intensive operation of the airplane causes elastic oscillations of the fuselage tail boom skin and stabilizer deforming the tail boom skin in the area of the stabilizer attachment fittings. Those deformations which may result in dents and fatigue cracks in the tail boom skin in the area of the stabilizer attachment fittings. To reduce the probability of creation of the dents and cracks it is necessary to increase the stiffness of the tail boom skin in the area of stabilizer attachment fittings using the reinforcing pads. **It is strongly recommended to avoid the resonance vibrations of the main landing gear.**

1.3) Subject

Fuselage tail boom skin in the area of stabilizer attachment fittings.

1.4) Compliance

Inspect the tail boom skin in the area of stabilizer attachment fittings.

1.5) Approval

The technical content of this Information Bulletin has been approved by Aeroprakt

1.6) Manpower

Estimated man-hours:

Work according to p. 3.1.2 is performed within 8 hours.

1.7) Mass data

Weight change – none (insignificant +60 g).

1.8) Revision of other documents

None

1.9) Spare parts

The reinforcing angles are supplied by the local dealer.

2) Spare parts information

2.1) Spare parts cost

Cost of the new parts: pad (2 pcs.) – free of charge, if cost of delivery is paid by the customer.

2.2) Special tooling / materials

For inspection of the tail boom no tools are required.

For repair: set of wrenches, drill bits: Ø3.0 mm, Ø3.1 mm, Ø4.0 mm, Ø4.1 mm, drill, Clico fasteners, riveting gun, primer.

3) Accomplishment / Instructions

3.1) Instructions

3.1.1) Inspection of the beam

1. Inspect the tail boom for dents and cracks in the specified area (see fig. 1).

If dents/cracks are found it is necessary to perform the repair work according to p. 3.1.2, otherwise carry out inspection regularly.

◆ **NOTE:** The tail boom must be inspected on both left and right sides, regardless the fact that the figures below show only the left side.

3.1.2) Tail boom skin straightening and installation of the reinforcing pad (doubler)

Prior to repair remove the stabilizer with elevator and rudder after disconnecting the control linkages.

1. Remove the fin.

- 1.1. Mark and drill $\varnothing 3$ mm hole for the rivet No. 23 in the stabilizer attachment plate No.3(4) (see fig. 11).

- 1.2. Drill out the rivets of fin attachment to the tail boom (No.11 – 6 pcs. see fig.1, 2, 3) with $\varnothing 4$ mm drill bit, and 8 rivets No.12 with $\varnothing 3$ mm drill bit. (Before drilling out the rivets beat out the rivets cores).

- 1.3. Drill out with $\varnothing 3$ mm drill bit the rivets of rib attachment to the fin spar (see fig. 1, 3, 4, 6, views C and B, No.13 – 2 pcs., No.14 – 6 pcs., No.15 – 3 pcs.).

- 1.4. Drill out with $\varnothing 3$ mm drill bit the rivets of skin attachment to the fin spar (see fig. 1, 3, 5 detailed views III and IV, No.16 – 6 pcs., No.17 – 36 pcs., No.18 – 10 pcs.).

- 1.5. Carefully remove the fin upward.

2. Drill out the rivets of the tail boom.

- 2.1. Drill out the rivets of the tail boom frames (see fig. 1, 4, 9, 10, detailed views II and III, No.19 – 8 pcs. with $\varnothing 3$ mm drill bit and No.20 – 6 pcs. with $\varnothing 4$ mm drill bit.

- 2.2. Remove the stabilizer attachment plate (see fig. 11 No.3(4)) by drilling out the rivets No.21 – 6 pcs. with $\varnothing 4$ mm drill bit.

- 2.3. Drill out the rivets of the upper longitudinal joint of the tail boom (see fig. 2, 7, 8, view E and A No.22 – 32 pcs. with $\varnothing 3$ mm drill bit).

- 2.4. Unclose the tail boom and insert a foam spacer of approx. 100 mm thickness for convenient access in the area of the Fr.5 (see fig.1).

3. Tail boom repair.

- 3.1. Straighten the tail boom skin in the detailed view III (see fig.1).

- 3.2. Make doublers of aluminum sheet 1 mm thick using the template of fig.12, mark the rivet holes and bend the doublers so that they fit to the tail boom contour on the left and right sides.

- 3.3. Put the doublers No.1(2) inside the tail boom and drill $\varnothing 3$ mm hole for the rivet No.23, insert Clico fastener.

- 3.4. Drill the $\varnothing 4$ mm hole for the rivet No.21. Take the doubler out.

- 3.5. Put the doubler No.1(2) outside on the tail boom, fix it with Clico fasteners at the drilled holes and drill the marked $\varnothing 3.1$ mm holes in the doubler and the tail boom for the rivets No.24.

- 3.6. Put the doubler No.1(2) inside the tail boom using Clico fasteners.

- 3.7. Mark and drill the $\varnothing 3.1$ mm holes for the rivets No.25 (see fig. 11). Insert Clico fasteners.

- 3.8. Drill the $\varnothing 3.1$ mm holes for the rivets No.12 in the doublers No.1(2) using holes in the tail boom.
- 3.9. Remove the doubler and clean it from metal chips.
- 3.10. Coat with primer the doubler on both sides and area of the tail boom where it is attached.
- 3.11. Fix with Clico fasteners the doubler No.1(2) inside the tail boom and stabilizer attachment plate No.3(4) (see fig. 11), set percussion rivets No.21 – 6 pcs., No.23 – 2 pcs., No.24 – 12 pcs., No.25 – 6 pcs.
4. Closing the tail boom.
 - 4.1. Remove the foam spacer.
 - 4.2. Assemble the tail boom using Clico fasteners.
 - 4.3. Set the rivets (see fig. 2, 4, 7, 8, 9, 10) No.22 – 32 pcs., No.20 – 6 pcs., 19 – 8 pcs.
5. Installation of the fin.
 - 5.1. Fix the fin with the Clico fasteners.
 - 5.2. Set rivets (see fig. 1, 2, 3, 4, 5, 6) No.11 – 6 pcs., 12 – 8 pcs., 13 – 2 pcs., 14 – 6 pcs., 15 – 3 pcs., 16 – 6 pcs., 17 – 36 pcs., 18 – 10 pcs.

NOTE: () – mirrored part.

4) **Appendix:**
The figures below contain additional information.

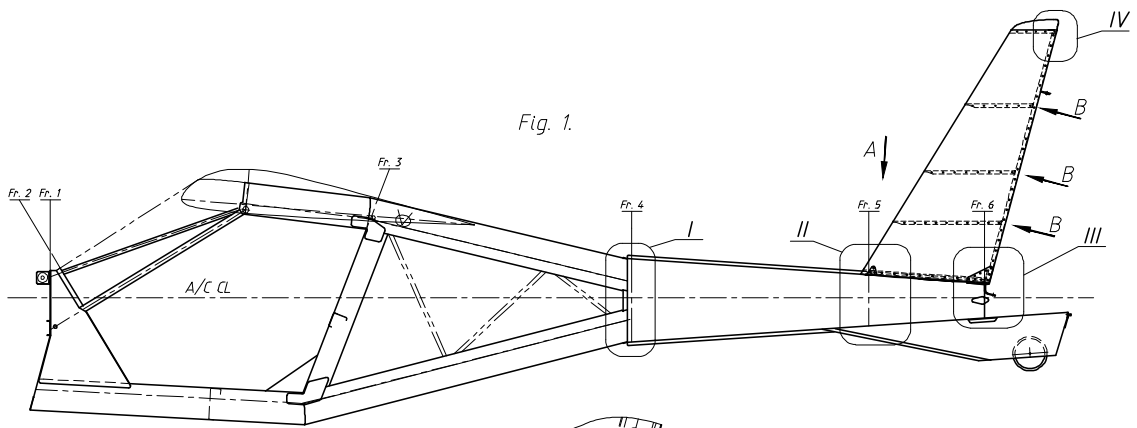

Fig. 1.

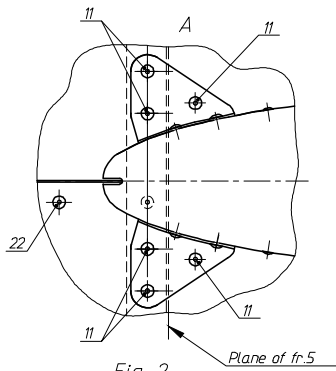

Fig. 2.

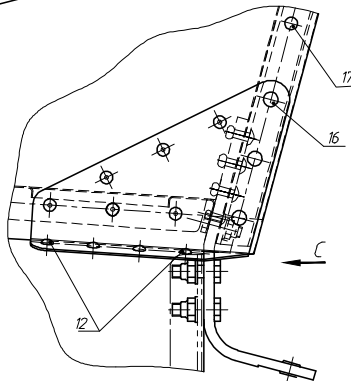

Fig. 3.

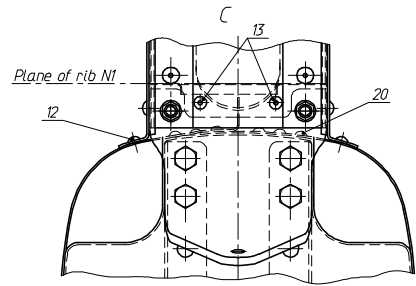

Fig. 4.

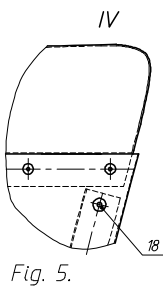

Fig. 5.

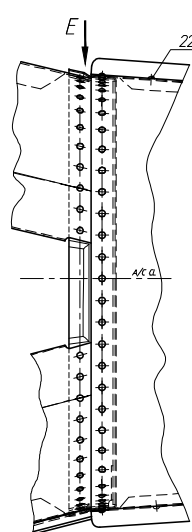

Fig. 7.

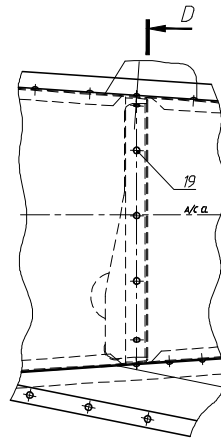

Fig. 9.

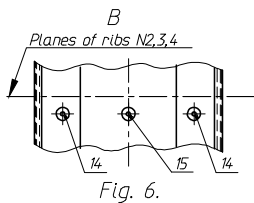

Fig. 6.

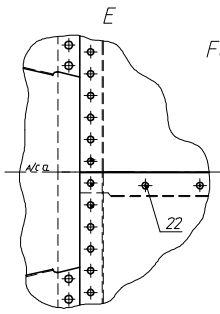

Fig. 8.

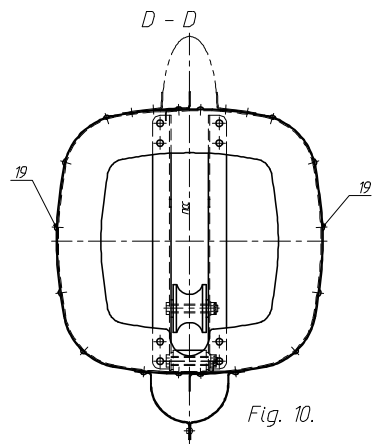

Fig. 10.

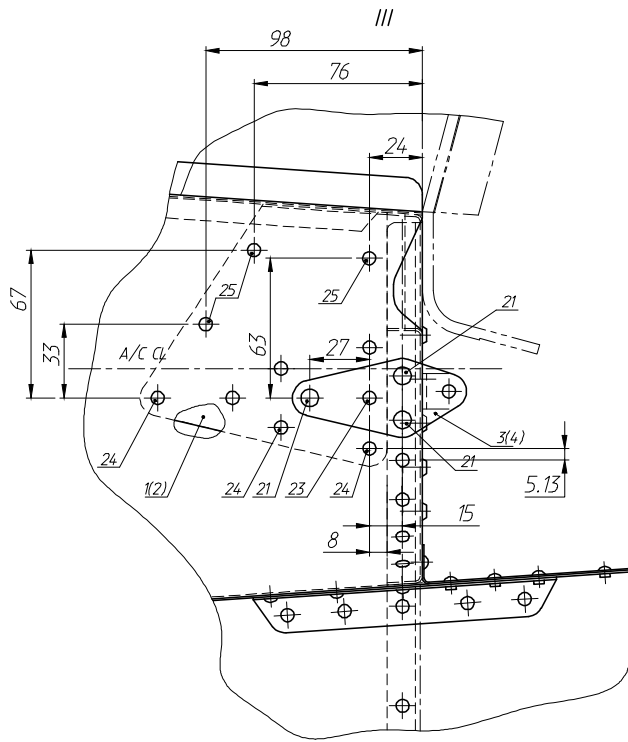

Fig. 11.

Ref No.	Format	Description	Qty
<i>Parts</i>			
1		<i>Doublers (left)</i>	1
2		<i>Doublers (right)</i>	1
<i>Standard parts</i>			
11		<i>Pap rivet 4-8 01010004008</i>	6
12		<i>Pap rivet 3-6 01010003006</i>	8
13		<i>Pap rivet 3-12 01010003012</i>	2
14		<i>Pap rivet 3-8 01010003008</i>	6
15		<i>Pap rivet 3-6 01010003006</i>	3
16		<i>Rivet 3-8-AH.Oxc. OCT1 34078-80</i>	6
17		<i>Rivet 3-7-AH.Oxc. OCT1 34078-80</i>	36
18		<i>Pap rivet 3-6 01010003006</i>	10
19		<i>Pap rivet 3-8 01010003008</i>	8
20		<i>Pap rivet 4-8 01010004008</i>	6
21		<i>Rivet 4-9-AH.Oxc. OCT1 34078-80</i>	6
22		<i>Pap rivet 3-6 01010003006</i>	32
23		<i>Rivet 3-8-AH.Oxc. OCT1 34078-80</i>	2
24		<i>Rivet 3-6-AH.Oxc. OCT1 34078-80</i>	12
25		<i>Rivet 3-6-AH.Oxc. OCT1 34078-80</i>	6

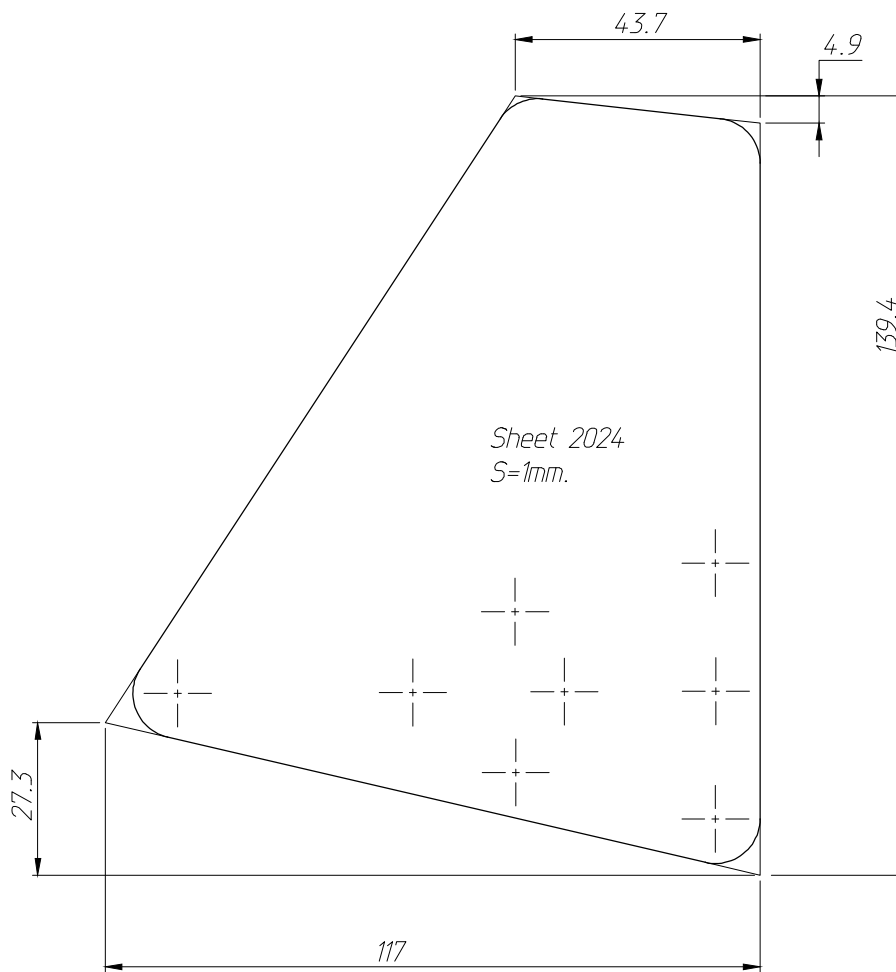

Fig. 12.